

•第37组 家族词汇: tra/tract

tract _____ /'træktə (r)/*n.* 拖拉机

_____ /ə'trækt/*v.* 吸引

attract _____ /ə'træktiv/*adj.* 吸引人的

attrac _____ /ə'trækʃn/*n.* 吸引人的事或物

_____ tract/dɪ'strækt/*v.* 转移; 使分心

_____ traction/dɪ'strækʃn/*n.* 分散注意力的事; 娱乐, 消遣

_____ tract/'kɒntrækt/*n.* 合同 *v.* 签订合同

_____ tract/'æbstrækt/*adj.* 抽象的 *n.* 摘要

_____ /træk/*n.* 轨道; 足迹 *v.* 跟踪; 追踪

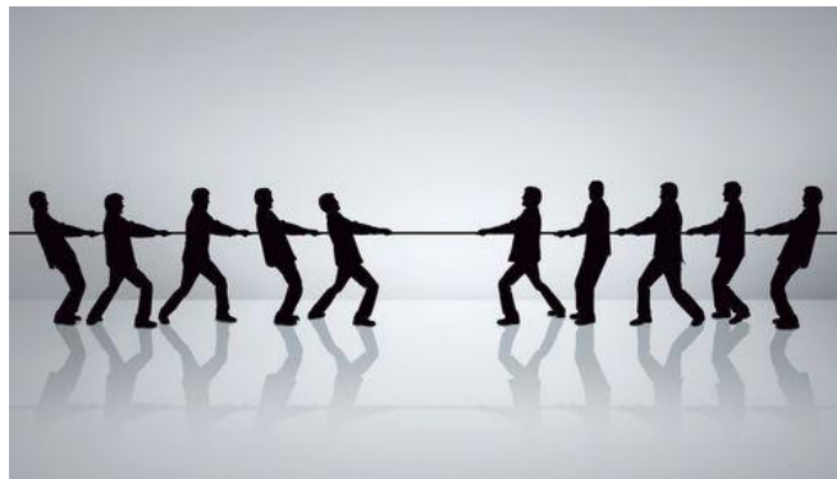

eg: employees who interact with their colleagues share meaningful work experiences, but those making connections outside the organization are distracted and unproductive.(2022.6)

•第38组 家族词汇: st/sist

_____ /ə'sɪst/v. 帮助; 援助; 促进

assist _____ /ə'sɪstənt/n. 助手

_____ /ɪn'sɪst/v. 坚持

_____ /rɪ'zɪst/v. 抵制

resist _____ /rɪ'zɪstəns/n. 抵制

_____ /kən'sɪst/v. 由……组成; 存在于

consist _____ /kən'sɪstənt/adj. 一致的

_____ /pə'sɪst/v. 顽强地坚持; 维持; 持续存在

persist _____ /pə'sɪstənt/adj. 执着的

_____ /ɪg'zɪst/v. 存在

exist _____ /ɪg'zɪstəns/n. 存在

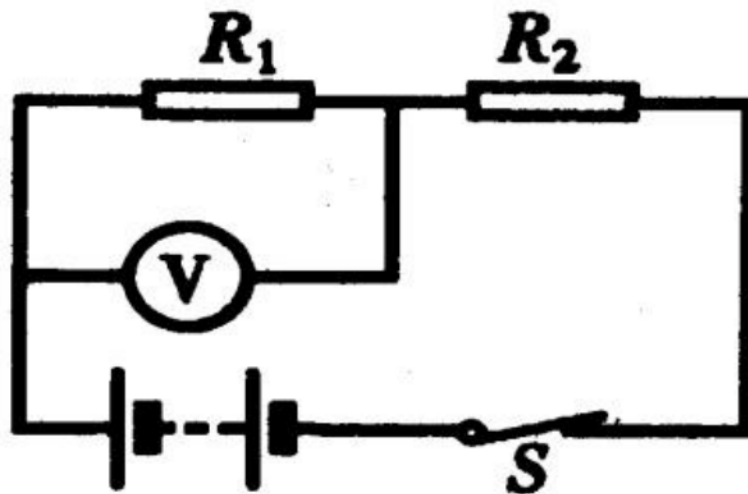

eg: As remote work is largely unobservable to supervisors, employers need to think about how they can objectively measure the quality of work in a way that is consistent for employees of similar rank.(2022.9)

•第39组 家族词汇: miss/mit

mis _____ /'mɪʃn/n. 任务

_____ mit/səb'mɪt/v. 提交, 呈递

_____ mit/træns'mɪt/v. 输送; 传播

_____ mit/i'mɪt/v. 排放; 散发 (光、热、气等)

emis _____ /i'mɪʃn/n. 排放 (物)

_____ /kə'mɪt/v. 犯, 干, 做; 承诺; 委托

commit _____ /kə'mɪtmənt/n. 承诺

commit _____ /kə'mɪti/n. 委员会

_____ mit/əd'mɪt/v. 承认; 接收 (入学); 录取

admis _____ /əd'mɪʃn/n. 承认; 准许加入

_____ /pə'mɪt/v. 允许

permis _____ /pə'mɪʃn/n. 准许; 许可



Perhaps this is because older people had fewer
ons when they were starting their careers, at a time
n values focused more on stable incomes than 32
onal missions.(2022.9)

•第40组 家族词汇: ac/ag

_____ /ækt/n. 行为; 法令 v. 行动; 扮演; 假装; 起作用

ac _____ /'ækʃn/n. 行动

ac _____ /'æktɪv/adj. 积极的

ac _____ /æk'tɪvəti/n. 活动

ag _____ /'eɪdʒənt/n. 代理人

ag _____ /'eɪdʒənsi/n. 机构; 中介

_____ /ə'dʒendə/n. 议程

_____ act/ɪntər'ækt/v. 互相影响

_____ active/ɪntər'æktɪv/adj. 交互式的; 互动的

_____ action/ɪntər'ækʃn/n. 相互作用

_____ act/ri'ækt/v. 反应

_____ action/ri'ækʃn/n. 反应

_____ act/træn'zækt/v. 办理; 交易

_____ action/træn'zækʃn/n. 交易; 办理



Professor Wilding disagrees that labelling a high proportion of the population having a disease removes responsibility or may overwhelm health services, but that other common diseases, such as high blood pressure and diabetes, require people to take action to manage their condition.(2021.12)

•第41组 家族词汇: dict

_____ /prɪ'dɪkt/v. 预言; 预报

predic _____ /prɪ'dɪkʃn/n. 预言; 预报

predict _____ /prɪ'dɪktəbl/adj. 可预见的

_____ /dɪk'teɪt/v. 口述; 强行规定; 命令

_____ /'ædɪkt/v. 使沉溺; 使上瘾 n. 上瘾的人

addic _____ /ə'dɪkʃn/n. 入迷

eg: They tell us the methods their forefathers used to predict the weather don't seem to work as well these days.(2023.6.3)

•第42组 家族词汇: en

- _____ courage /m'kʌrɪdʒ/ v. 鼓励
- _____ /ɪn'ʃʊə (r)/ v. 保证; 确保
- en _____ /ɪ'neɪbl/ v. 使能够
- _____ /ɪn'hɑ:ns/ v. 提高; 增强
- en _____ /ɪn'taɪtl/ v. 使享有权利; 叫做……
- en _____ /ɪn'dʒɔɪ/ v. 享受; 享有
- enjoy _____ /ɪn'dʒɔɪəbl/ adj. 使人快乐的; 令人愉快的
- en _____ /ɪn'dʒʊə (r)/ v. 忍耐; 忍受
- en _____ /ɪn'la:dʒ/ v. 扩大; 扩充
- en _____ /ɪn'rɪtʃ/ v. 使丰富
- en _____ /ɪn'lɑɪtn/ v. 启发, 启蒙; 教导
- en _____ /ɪn'deɪndʒə (r)/ v. 危及
- en _____ /ɪn'fɔ:s/ v. 迫使
- wors _____ /'wɜ:sn/ v. 恶化
- _____ /'streŋθn/ v. 加强; 强化
- _____ /'di:pən/ v. 变强烈; 深化
- _____ /'brɔ:dn/ v. 加宽; 扩大
- _____ /'taɪtn/ v. (使) 变紧; 使严格
- _____ /'lu:sn/ v. (使) 变松



eg: Recent open debates on scientific research, health, and policy have aroused greater public attention and encouraged more diverse voices.(2022.6.1)

•第43组 家族词汇: serv

_____ /sɜ:v/v. 招待; 服务; 可用作……

_____ /'sɜ:vɪs/n. 服务; 仪式; 服役

_____ /ɪ'zɜ:v/v. 预订

reserv _____ /,rezə'veɪʃn/n. 预订

_____ /prɪ'zɜ:v/v. 保护

_____ /dɪ'zɜ:v/v. 应得

_____ /kən'sɜ:v/v. 保护

conserv _____ /,kɒnsə'veɪʃn/n. 保护

conserv _____ /kən'sɜ:vətɪv/adj. 保守的

_____ /əb'zɜ:v/v. 注意到

observ _____ /,ɒbzə'veɪʃn/n. 观察



eg: He built a large consultation service to address the holistic (整体的) needs of hospitalized patients, including psychological and social factors."(2022.9)

•第44组 家族词汇: soci

_____ /'səʊʃl/ *adj.* 社会的, 社会学的; 社交的

_____ /sə'saɪəti/ *n.* 社会; 协会

_____ /ə'səʊʃieɪt/ *v.* 使联系 *adj.* 副的 *n.* 合伙人

_____ /ə,səʊʃi'eɪʃn/ *n.* 协会, 团体; 联系, 交往

_____ /'səʊʃəlaɪz/ *v.* 交往; 使适应社会

eg: There's a social dimension to health that we've completely overlooked in our efforts to find the best and most cutting-edge medical care ... (2022.9)

•第45组 家族词汇: ver/vers

- _____ /'vɜ:ʃn/n. 版本; 译文
- _____ verse/'ju:nɪvɜ:s/n. 宇宙
- _____ vers _____ /ju:nɪ'vɜ:sl/adj. 普遍的
- _____ /daɪ'vɜ:səti/n. 多样性; 差异
- _____ /daɪ'vɜ:s/adj. 多样的; 不同的
- _____ vers _____ /,kɒntɹə'vɜ:ʃl/adj. 有争议的
- _____ versary/|æni'vɜ:səri/n. 周年纪念日
- _____ /rɪ'vɜ:s/v. 颠倒, 扭转; 彻底转变; 倒车
- _____ revers _____ /,rɪ'vɜ:səbl/adj. 不可逆转的; 不能挽救的



eg: While cheek-kissing for Latin Americans is also a universal greeting form, it does not require such a high degree of relational closeness. (2021.12.3)

•第46组 家族词汇: load

_____ /ləʊd/*n.* 负荷; 工作量 *v.* 装载

_____ load/ˌəʊvəˈləʊd/*v.* 超负荷; 使超载; 使负荷过重

_____ /ˌdaʊnˈləʊd/*v.* 下载

_____ load/ˌʌpˈləʊd/*v.* 上传

_____ load/ˈwɜːkləʊd/*n.* 工作量

eg:



•第47组 家族词汇: **flect**

flex _____ /'fleksəbl/ *adj.* 灵活的

_____ flexible/ɪn'fleksəbl/ *adj.* 僵化的

flex _____ /,fleksə'bɪləti/ *n.* 柔韧性

_____ /rɪ'flekt/ *v.* 反映; 反射; 反思

reflec _____ /rɪ'flekʃn/ *n.* 反思; 反映



eg: Qualities like flexibility and the ability to work under minimal supervision might become critical.(2022.6.2)

•第48组 家族词汇: crit

critic _____ /'krɪtɪsaɪz/v. 批评

critic _____ /'krɪtɪsɪzəm/n. 批评

crit _____ /'krɪtɪk/n. 评论家

_____ /'krɪtɪkl/adj. 批评的; 关键的; 极为重要的

criter _____ /kraɪ'tɪəriən/n. 准则

eg: Qualities like flexibility and the ability to work under minimal supervision might become critical.(2022.9)

•第49组 家族词汇: migr

migr _____ /maɪ'greɪt/v. 迁移; 迁徙

migra _____ /maɪ'greɪʃn/n. 迁移; 移居; 迁徙

migr _____ /'maɪgrənt/n. (为工作) 移居者; 移民; 候鸟

_____ migr _____ /'ɪmɪgrənt/n. (外来) 移民; 外侨

_____ migra _____ /,ɪmɪ'greɪʃn/n. 移居 (入境); 移民人数

_____ migr _____ /'emɪgreɪt/v. 移居国外; 移民

eg: The U.S. was founded by successive waves of immigrants, and immigrants are still contributing to America today—statistics prove it. (2023.6.2)

•第50组 家族词汇: norm

_____ /nɔ:m/n. 准则

norm _____ /'nɔ:ml/adj. 正常的; 一般的

_____ norm _____ /æb'nɔ:ml/adj. 反常的

_____ norm _____ /ɪ'nɔ:məs/adj. 巨大的

eg: In the coming era of budget cuts to education, distance learning could become the norm.(2022.6.2)

•第51组 家族词汇: vis/vit

vis _____ /'vɪzəbl/ *adj.* 看得见的

_____ vis _____ /ɪn'vɪzəbl/ *adj.* 看不见的

_____ /'vɪʒn/ *n.* 视野; 想象, 憧憬; 远见

vis _____ /'vɪʒuəl/ *adj.* 视觉的

_____ /əd'vaɪs/ *v.* 劝告; 建议

advis _____ /əd'vaɪzəbl/ *adj.* 明智的

_____ /rɪ'vaɪz/ *v.* 复习; 修改

_____ vise/ 'su:pəvaɪz/ *v.* 监督

supervis _____ /'su:pəvaɪzə (r)/ *n.* 监督人

eg: Fraudsters target popular seaside destinations for British tourists visiting Spain where prices can soar if demand exceeds supply.(2022.6.2)

•第52组 家族词汇: multi

_____ /'mʌltɪpl/ *adj.* 数量多的

_____ /'mʌltɪplaɪ/ *v.* 乘以; 成倍增加; 增殖

multi _____ /,mʌlti'mi:diə/ *adj.* 多媒体的

multi _____ /,mʌlti'ta:sk/ *v.* 多任务

eg: Employees with a growth mindset may be more likely to devise innovative ideas that bridge multiple areas of knowledge to achieve better solutions."(2021.12.3)

•第53组 家族词汇: dom

_____ /də'mestɪk/ *adj.* 本国的; 家庭的

_____ /'dɒmɪneɪt/ *v.* 支配; 统治; 主导

domestic _____ /də'mestɪkeɪt/ *v.* 驯养; 驯化; 使归化

_____ dom/'frɪ:dəm/ *n.* 自由

_____ dom/'wɪzdəm/ *n.* 才智

_____ dom/'seldəm/ *adv.* 很少

_____ /'rændəm/ *adj.* 随机的; 任意的; 胡乱的

eg: For example, the United Nations reported that women do nearly three times as much unpaid domestic work as men..(2021.12.1)

•第54组 家族词汇: rupt

- _____ rupt/ˌɪntəˈrʌpt/v. 打断; 中断; 插嘴
- _____ rupt _____ /ˌɪntəˈrʌpʃn/n. 打扰; 插嘴
- _____ rupt/ɪˈrʌpt/v. 爆发; 喷出
- _____ /əˈbrʌpt/adj. 突然的; 唐突的; 生硬的
- _____ rupt/ˈbæŋkrʌpt/adj. 破产的; v. 使破产 n. 破产者
- _____ rupt/kəˈrʌpt/adj. 贪污的; 腐败的 v. 使腐化, 堕落; 破坏
- _____ ruptive/dɪsˈrʌptɪv/adj. 颠覆性的; 破坏性的

eg: Uncontrolled tourism development has become a primary driver of social and environmental disruption.(2022.9)

•第55组 家族词汇: point

_____ /pɔɪnt/n. 观点; 重点; 目的; 地点; 分数 v. 指向

_____ /ə'pɔɪnt/v. 任命; 指定; 约定

_____ point _____ /ə'pɔɪntmənt/n. 约定; 任命

_____ appoint/ɪdɪsə'pɔɪnt/v. 使失望

_____ appoint _____ /ɪdɪsə'pɔɪntmənt/n. 失望

eg: He points out that more
than 200genes influence weight.(2021.12.2)

•第56组 家族词汇: sci

_____ /'kɒnʃəs/ *adj.* 意识到的

_____ conscious/ʌn'kɒnʃəs/ *adj.* 无知觉的

conscious _____ /'kɒnʃəsnəs/ *n.* 意识; 知觉

_____ conscious/ɪsʌb'kɒnʃəs/ *adj.* 潜意识的

_____ /ə'weə (r)/ *adj.* 意识到的; 知道的; 明白的

_____ aware/ɪʌnə'weə (r)/ *adj.* 没意识到的

aware _____ /ə'weənəs/ *n.* 意识

eg: Women working outside of the home should make an effort to have a conscious conversation with their partners about more equitable sharing of household and family responsibilities,"Dr. Joyce said.(2021.12.1)

•第57组 家族词汇: equ

_____ /'i:kwəl/ *adj.* 同样的; 平等的

_____ /i'kwɒləti/ *n.* 平等; 相等

_____ /ˌɪni'kwɒləti/ *n.* 不平等, 不平衡

eg: This is an issue of equality, opportunity and national conscience.